

Turin Evening Ball Programme – 27th April 2024

1.	EH3 7AF	(J8x32)	Book 40
2.	Maxwell's Rant	(R8x32)	Book 18
3.	Rose of the North	(S8x32)	Leeds Silver Jubilee Roy Goldring
4.	Best Set in the Hall	(J8x32)	Book 46
5.	Swiss Lassie	(R8x32)	Book 39
6.	Aberdeenshire meets Argentina	(S3x32)	Argentine Collection J Stott
7.	Tribute to The Borders	(J8x32)	Leaflet 31 Goldring
8.	Tri-Mariner	(R8x32)	Ann Dix
9.	Schiehallion	Medley S64S S64	Thurston
Break			
10.	A Capital Jig	(J8x32)	5 for 2009
11.	Teacher's Choice	(R8x32)	Jim Stott
12.	The Gentleman	(S8x32)	Book 35
13.	Welcome to Argentina	(J8x32)	Argentine Collection J Stott
14.	McDonald of Keppoch	(M S64 R64)	Bk 49
15.	Jean Martin of Aberdeen	(S3x32)	3 for 2006
16.	Gothenburg's Welcome	(J8x32)	Book 37
17.	Toast To The Mousies	(R8x32)	Book 53
18.	Highland Rambler	(R8 x 40)	Goldring

1) EH3 7AF (J8x32) 3C (4C set) Roy Goldring RSCDS Book 40

1- 8 1s lead down the middle and back to top

9-16 1s+2s+3s Promenade ending with 1s casting to 2nd place

17-24 1s pass by the right and turn 1st corners RH to end L between 2s and M between 3s, 1s pass by the right and turn 2nd corners RH to end between corners

25-32 1M dances RH across with 2s and 1L with 3s, 1L dances up between 2s and casts to 2nd place own side as 1M dances between 3s and casts up

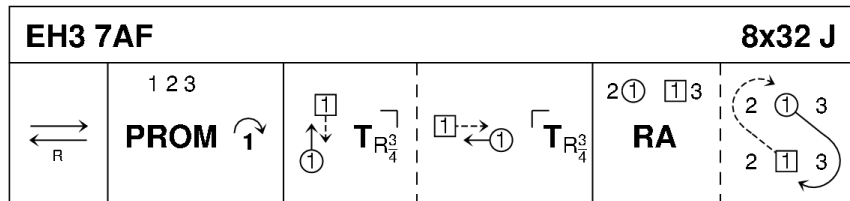

Roy Goldring, 1998, RSCDS Book 40.6

3C/4C longwise set.

2) MAXWELL'S RANT (R8x32) 3C (4C set) David Rutherford RSCDS Book 18

1- 8 1s cross down to dance reflection reels of 3 on opposite sides

9-16 1s cross down to dance reflection reels of 3 on own sides

17-24 1s cross RH, cast to 2nd place and dance 1/2 Fig of 8 round 2s

25-32 1s dance down between the 3s, cast up to 2nd place and 2s+1s+3s turn partners RH. 213

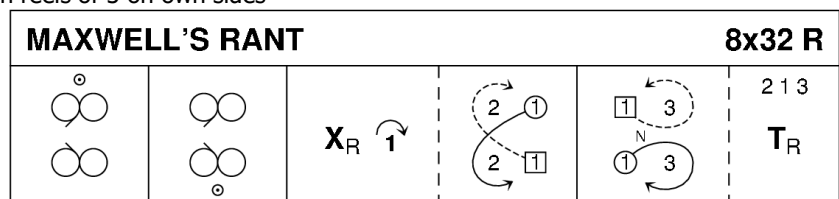

Rutherford, 1755, RSCDS Book 18.10

3C/4C longwise set.

3) THE ROSE OF THE NORTH (S8x32) 3C (4C set) Roy Goldring Leeds Silver Jubilee

1- 4 1s lead down below 3s, cross and cast up to 2nd place on opposite side

5-16 2s+1s+3s dance 3 couple R&L, 1s end facing 1st corners

17-24 1s set to and turn 1st corner 2H, set to and turn 2nd corner 2H. 1s finish BtoB in centre, 1M facing up, 1L facing down
25-32 1M+2s and 1L+3s circle 3H round to left and on bar 4 1s pull back RSh to face each other and set; 1s Petronella turn to 2nd place own side. 213

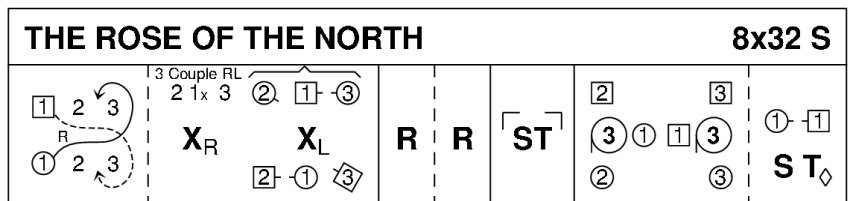

Roy Goldring, 1986, Leeds Silver Jubilee

3C/4C longwise set.

4) BEST SET IN THE HALL (J8x32) 3C (4C set) Helen Greenwood RSCDS Book 46

1- 8 1s set and 1L followed by partner casts below 3s. 1L crosses and casts up to face her 1st corner while 1M dances up the middle to face 1st corner

9-12 1s set to 1st corners and dance RSh round each other into 3rd corner (position) while 1st corners dance in and turn right about to face their original position

13-16 1s+1st corner person set and 1st corner persons dance RSh round each other into diagonal opposite corners while 1s dance in and pivot to right to face 2nd corners

17-24 1s repeat bars 9-16 with 2nd corners and end passing RSh to 2nd place opposite sides. (3)(1)(2)

25-32 3s+1s+2s chase clockwise 1/2 way and turn partners RH

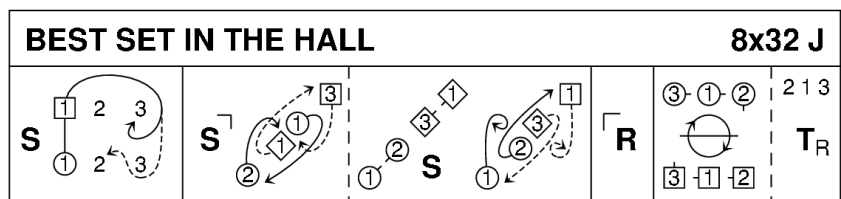

Helen Greenwood, 2003, RSCDS Book 46.7

3C/4C longwise set.

5) **SWISS LASSIE** (R8x32) 3C (4C set) Rosi Betsche RSCDS Book 39

1- 8 1s dance in and cast to 3rd place, 2s+1s turn partners RH 1¼ times to form a line up and down middle of set (Men facing down Ladies up)

9-16 2s+1s dance reel of 4 up and down middle of set ending with 2M facing Ladies' side and 1L facing Men's side

17-24 2s+1s chase round clockwise ½ way, 1s+3s+2s advance and retire

25-32 3s+2s (bottom 2 couples) ½ turn partners RH, dance RH across ½ way, 1s+2s (top 2 couples) ½ turn partners RH and dance RH across ½ way

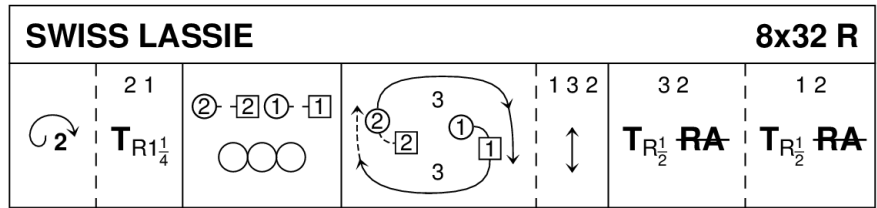

Rosi Betsche, RSCDS Book 39.1

3C/4C longwise set.

6) **ABERDEENSHIRE MEETS ARGENTINA** (S3x32) 3C Set James (Jim) Stott Argentine Collection 2020

1- 8 1s set, turn 2H and face down; 1s dance down and cast up round 3s to 2nd place own side (2s step up 5-6)

9-16 1s pass LSh to dance ½ diagonal reel of 4 with 1st corners, pass LSh to dance ½ diagonal reel of 4 with 2nd corners to end in 2nd place opposite sides. (3)(1)(2)

17-24 3s+1s+2s dance set and link for 3 couples twice. 213

25-32 1s+3s dance The Rosette:

1s+3s join nearer hands and set to partner, ½ turn partner RH remaining in centre facing partner; 1s+3s pull back RSh and chase clockwise ½ round. 231

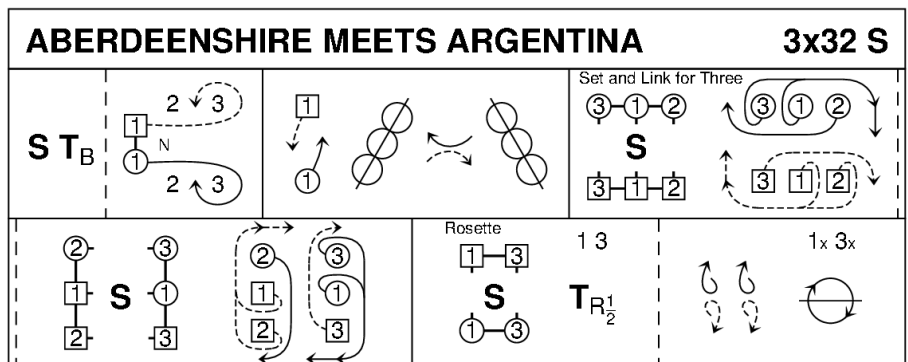

James Stott, 2019, The Argentine Collection 2020

3C/3C longwise set.

7) **TRIBUTE TO THE BORDERS** (J8x32) 3C (4C set) Roy Goldring RSCDS Leaflet Dances 31

1- 8 1s cross RH and cast 1 place, turn RH 1½ times to end in promenade hold facing 2M

9-16 1s dance ½ RSh reel of 3 on Man's side, cross to face 3L and dance ½ RSh reel on Ladies' side 1s end facing 3L (in top place), still in promenade hold

17-24 1s set to 3L, swivel right and set to 2L, set to 2M, set to 3M (2s+3s set advancing into centre) ready for...

25-32 3s+1s+2s Allemande. 213

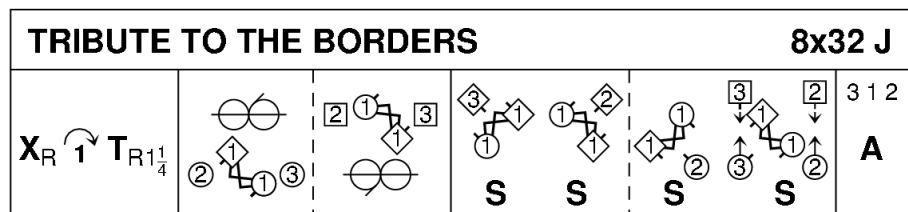

Roy Goldring, 1979, RSCDS Leaflet 11

3C/4C longwise set.

THE TRI-MARINER (R8x32) 3C (4C set) Ann Dix Reel Friends 2

1- 8 1s set, cast 2 places and lead up to top while 2s (bar 3) set, cast 1 place and lead up to 2nd place while 3s (bar 5) set, cast into middle

9-16 1s+2s+3s Promenade and end with 1s casting to 2nd place

17-24 1s cross down, cast up behind 3s, cross up and cast to 2nd place

25-32 All petronella turn into middle, set and turn partner RH 1¼ times

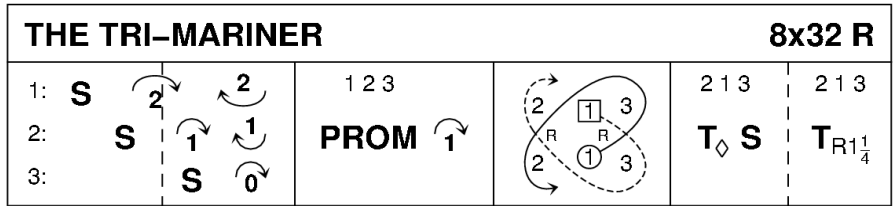

8) SCHIEHALLION (M-(S64+R64)) Sq.Set Hugh A Thurston RSCDS book 53

Strathspey

1-16 All dance Chorus:

Grand Chain ½ way, set Highland Schottische, Grand Chain ½ way and set Highland Schottische and Men end BtoB in the middle facing partners

17-24 Men set (rocking step) as Ladies petronella turn and set, petronella turn and set to move ½ way round set

25-32 Ladies change places RH with opposite Man, Ladies dance LH across ½ way and turn partners RH

33-48 Repeat bars 1-16 (Chorus)

49-56 All dance RH across ½ way (Men on outside), all change places with partners advancing 1 place and change places again advancing 1 more place

57-64 All repeat bars 49-56 back to places

Reel

1-16 All dance Chorus:

Grand Chain ½ way, turn partner with R arms twice, Grand Chain ½ way and turn partner R arms twice

17-32 1s+3s set advancing, turn opposite dancer and circle 4H round to left, 2s+4s repeat

33-48 Repeat bars 1-16 (Chorus)

49-64 All dance full Schiehallion Reel: (Men start by crossing to the right, Ladies cast and cross (following partner))

49-50 Men dance diagonally across set to next Ladies' position to their right while Ladies cast into partner's place

51-52 Men cast into Man's place while Ladies cross diagonally to Ladies' position to their right (following partner)

53-64 Repeat 3 more times back to original places

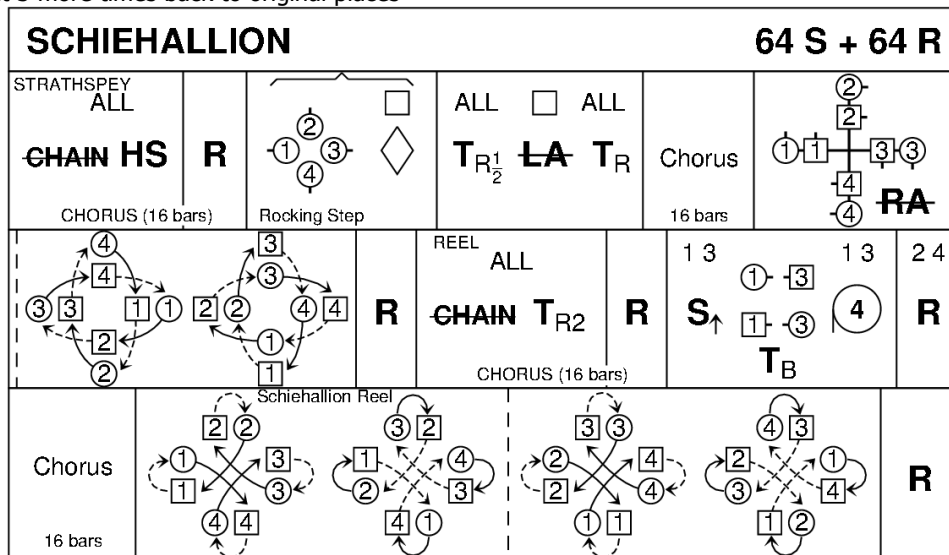

Hugh A Thurston, RSCDS Book 53, Leaflet

4C/4C square set.

*** INTERVAL ***

10) A CAPITAL JIG (J8x32) 3C (4C set) Tine E MacKay 5 dances 2009

1- 8 1s+2s set and rotate and end 1s facing up, 2s down:

Set, rotate singly and dance on 1 place clockwise, change places RH on sides and dance on 1 place to own sides (1s in 2nd place facing up)

9-16 1s dance reels of 3 on own sides (RSh to 2s)

17-24 1s set and turn $\frac{3}{4}$ RH to face own sides, 1s dance LH across (1L with 2s, 1M with 3s) to end 2nd place opposite sides

25-32 1s set and turn $\frac{3}{4}$ RH to face opposite sides, 1s dance LH across (1M with 2s, 1L with 3s) ending 2nd place own sides

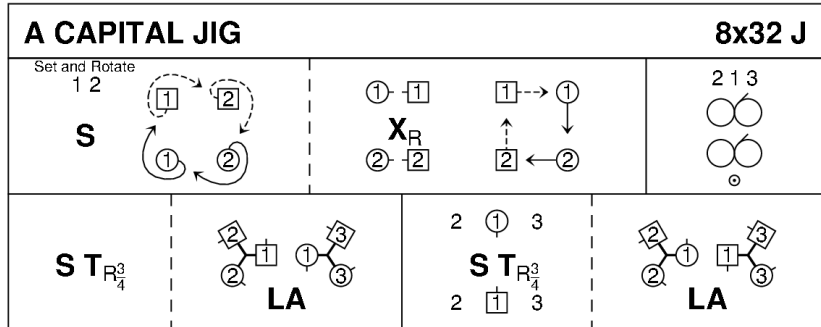

Tine Mackay, RSCDS 5/2009

3C/4C longwise set.

11) TEACHER'S CHOICE (R8x32)

Jim Stott

12) THE GENTLEMAN (S8x32) 3C (4C set) Roz Scott Huxley 1986 RSCDS Book 35

1- 8 1s turn 2H and remain in middle facing each other as 2s step up, 1s+2s set (1s advancing and pass LSh to face opposite partner) and dance $\frac{1}{2}$ reel of 4 across with 2s with 1s ending reel giving LH to face down on own side between 2s

9-16 1s dance down to end between 3s and face each other, 1s+3s set (1s advancing and pass LSh to face opposite partner) and $\frac{1}{2}$ reel of 4 across with 3s 1s end giving LH to face up on own side between 3s

17-24 1s lead up to top, cross over and cast to 2nd place and $\frac{1}{2}$ reels of 3 across (L with 2s and M with 3s)

25-32 2s+1s dance Diamond Poussette. 213

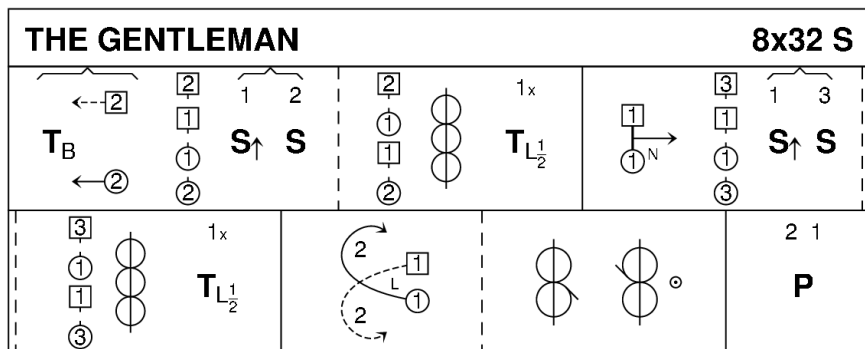

Roz Scott Huxley, 1986, RSCDS Book 35.5, RSCDS Thirty Popular Dances Vol 2

3C/4C longwise set.

13) WELCOME TO ARGENTINA (J8x32) 3C (4C set) James (Jim) Stott Argentine Collection 2020

1- 8 1s dance in, cast to 2nd place (2s step up 3-4); 1s set advancing and $\frac{3}{4}$ turn 1st corners RH to 1L between 2s, 1M between 3s all facing down

9-16 Line of 3 across dance down; pull back RSh and dance up to finish 1L between 2s facing down, 1M between 3s facing up

17-28 All dance R&L for 3 couples:

17-18 All 3 couples cross RH with dancer opposite

19-20 Dancers in 1M place and 3L place change places diagonally LH while other couples change places LH on side

21-28 Repeat bars 1-4 from new places twice to end 1L between 2s at top, 1M between 3s at bottom

29-32 1s turn $1\frac{1}{4}$ RH to 2nd place own side. 213

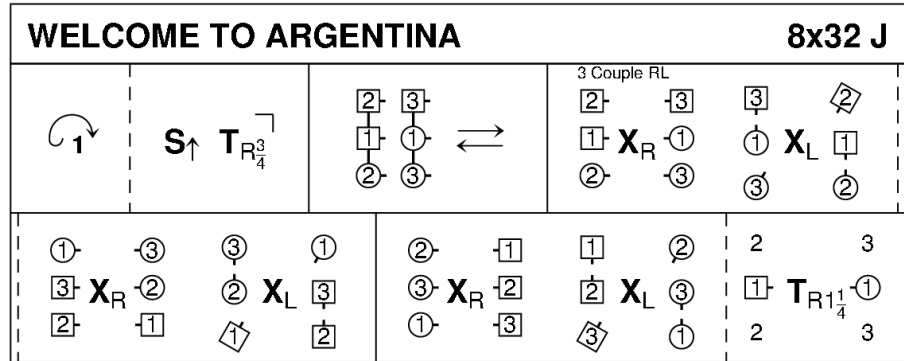

James Stott, 2019, The Argentine Collection 2020

3C/4C longwise set.

14) MACDONALD OF KEPPOCH (M-(S64+R64)) Sq.Set Chris Ronald RSCDS Book 49

Strathspey

1- 8 1s+3s dance 6 bars R&L (Men polite turns) to finish in centre BtoB with partner facing side couples (1L+2L, 1M+4M, 3L+4L, 3M+2M). All set

9-16 Reels of 4 across. Finish in line up/down with Ladies (in middle) facing, 1M facing down, 3M facing up

17-24 Reel of 4 (1L+3L pass RSh)- all pass LSh at ends, RSh in middle. Finish in original places facing partners

25-32 All set, all turn partner RH $1\frac{1}{4}$ into promenade hold and dance 1 place anticlockwise

Repeat from new positions in Strathspey then twice in Reel time back to original places

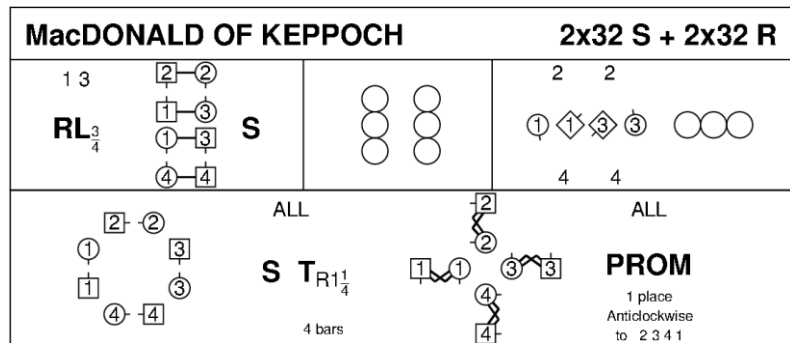

Chris Ronald, 2013, RSCDS Book 49.11

4C/4C square set.

15) JEAN MARTIN OF ABERDEEN (S3x32) 3C set Muriel A Johnstone 3 Dances 2006

1- 8 1s turn RH and cast 1 place, all circle 6H round $\frac{3}{4}$ way to left and end in lines of 3 across (Ladies face down and Men up)

9-16 All set and change places with partner RH, all circle 6H round $\frac{3}{4}$ way to left and end in middle facing up. 312

17-24 All dance Allemande. 213

25-32 1s+3s (bottom 2 couples) dance the Bourrel:

1M+3L set advancing, $\frac{3}{4}$ turn 2H and twirl to end BtoB (up/down middle L facing up and M down) while 1L+3M chase anticlockwise $\frac{1}{2}$ way to face partner

1s+3s set to partners and turn 2H to own sides having changed places. 231

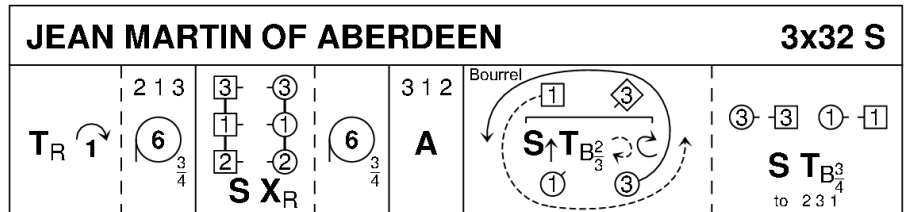

Muriel A Johnstone, 2004, RSCDS 3/2006

3C/3C longwise set.

16) GOTHENBURG'S WELCOME (J8x32) 3C (4C set) Bobby Munro RSCDS Book 37

1- 4 1s cast 1 place and set advancing to 1st corner

5-16 Dance to Corners and Set (12 bars):

Couple in middle change places with corners passing RSh, corners pass RSh in middle with a $\frac{1}{4}$ turn to right to face next corner while supporting corners set (2 bars). Repeat 5 more times to end with corners in diagonally opposite place and 1s in the middle facing 3rd corner positions

17-24 1s dance $\frac{1}{2}$ diagonal Reel of 4 with 3rd corner, pass RSh and dance $\frac{1}{2}$ diagonal Reel with 4th corners

25-32 1s dance RH hands across (L with 2s and M with 3s) and 2s+1s+3s turn RH

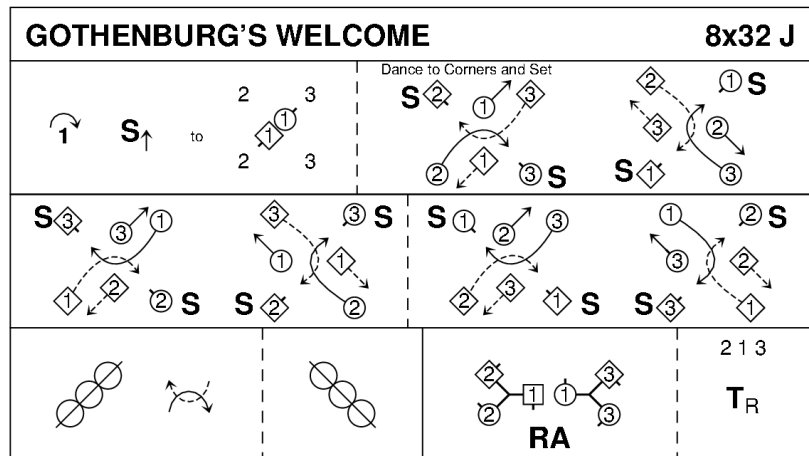

Bobby Munro, RSCDS Book 37.3

3C/4C longwise set.

17) TOAST TO THE MOUSIES (R8X32) 3C (4C set) Sara Gratiot RSCDS book 53

1- 8 1s dance in and cast 1 place (2s step up), dance down between 3s and cast up to 2nd place

9-16 2s+1L also 1M+3s dance RH across and 1s pass RSh to dance LH across with other couple, 1s end back to back in the middle (1M facing up, 1L down) facing 2s/3s (2s facing down, 3s up nearer hands joined)

17-20 All set, 2s and 3s make arches, dance down/up to meet as 1s dance under arches. Finish 1M in 1st place, 1L in 3rd place (facing down/up) and 2s and 3s back to back in middle nearer hands joined (2s facing up, 3s down).

21-24 All set, 2s and 3s making arches dance to ends and cast into reel while 1s dance under arch passing LSh and finish between end couple facing 1st corner

25-32 2s+1L also 1M+3s dance LSh reels across (2s+3s make loops into the reel) to end 213. All set

Note: after 2nd time through 1s may repeat bars 1-4 to get to 4th place

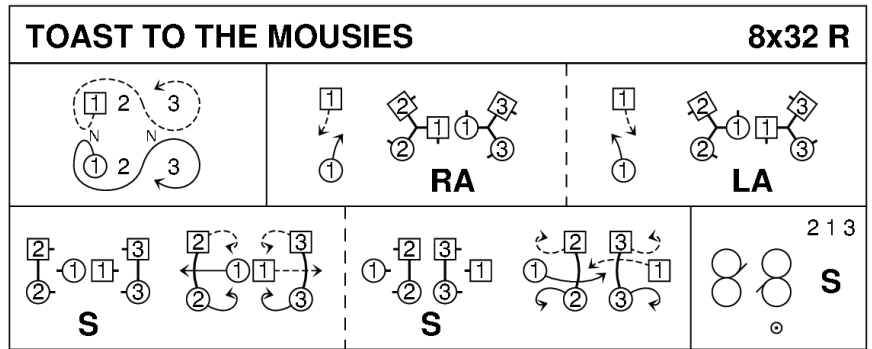

Sara Gratiot, 2016, RSCDS Book 53

3C/4C longwise set.

18) THE HIGHLAND RAMBLER (R8x40) 3C (4C set) Roy Goldring Leeds Silver Jubilee 1987

1- 8 1s dance in and cast to 2nd place, dance RH across with 3s

9-16 2s+1s dance LH across, 1L followed by partner cast up round 2L and dance down middle to 1L between 3s and 1M between 2s

17-24 1s+2s+3s dance down the middle and back

25-32 1M followed by partner dance up, cast down round 2L to 2nd places on own side and turn RH

33-40 2s+1s+3s circle 6H round and back

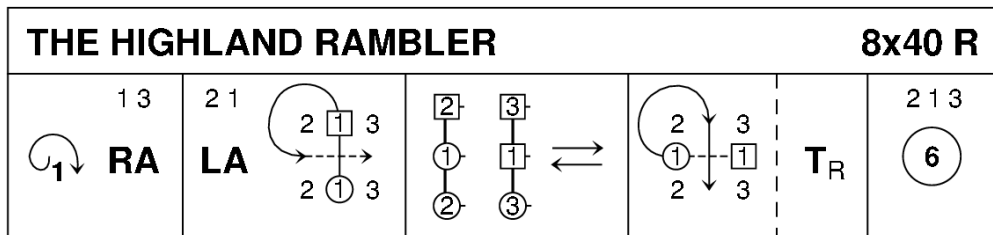

Roy Goldring, 1985, Leeds Silver Jubilee, RSCDS Thirty Popular Dances Vol 2

3C/4C longwise set.