

TURIN CLIVIS GRAN BALL – 25th ANNIVERSARY 2016

The Jubilee Jig

THE JUBILEE JIG (J8x32) 3C (4C set) RSCDS Leaflet Dances 11

1- 8 1M casts to 2nd place, sets to 3L, turns RH and dances back to 2nd place on own side

9-16 1L casts to 2nd place, sets to 3M, turns LH and dances back to 2nd place

17-24 1L with 2s and 1M with 3s dance RH across, 1s end in centre LH joined, 1s set in centre and dance out to 2nd place on opposite sides

25-32 1M with 2s and 1L with 3s dance RH across, 1s end in centre LH joined, 1s set in centre and dance out to 2nd place on own sides

(MINICRIB, Dance Crib compiled by Charles Upton, Deeside Caledonian Society, and his successors)

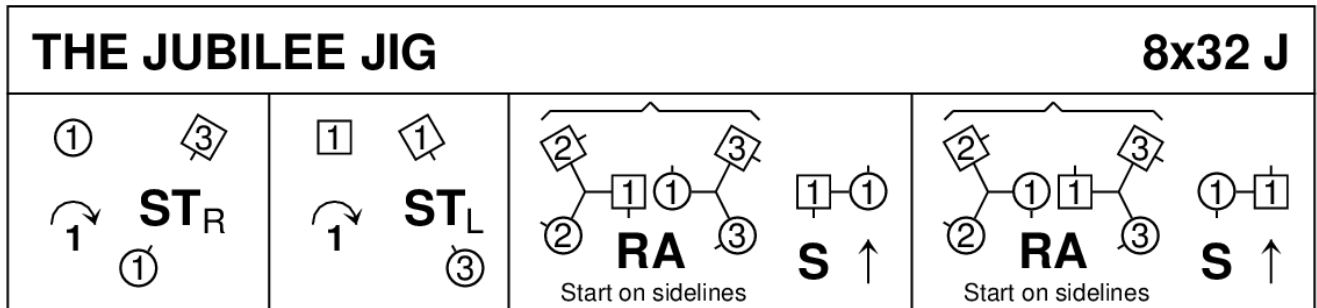

1973, RSCDS Leaflet 19

3C/4C longwise set.

The Saltire Society Reel

THE SALTIRE SOCIETY REEL (R8x32) 3C (4C set) Roy Goldring RSCDS Leaflet Dances 28

1- 8 1s cross down and dance out between 2s+3s turning 3s by near hand to meet partner, dance up and turn 2s by nearest hand to 2nd place opposite sides

9-16 1s cross down to 3rd place and dance reel of 3 own side (2s dance out and down as 3s dance in and up between 2s), 1s end (hold LH) facing 1st corners

17-24 1s set to 1st corners, turn inwards and set to 3rd corner as 3rd corners set adv to dance RH across with 1s, 1s end turning to face 2nd corners

25-32 1s repeat bars 17-24 with 2nd/4th corners but dancing LH across

(MINICRIB, Dance Crib compiled by Charles Upton, Deeside Caledonian Society, and his successors)

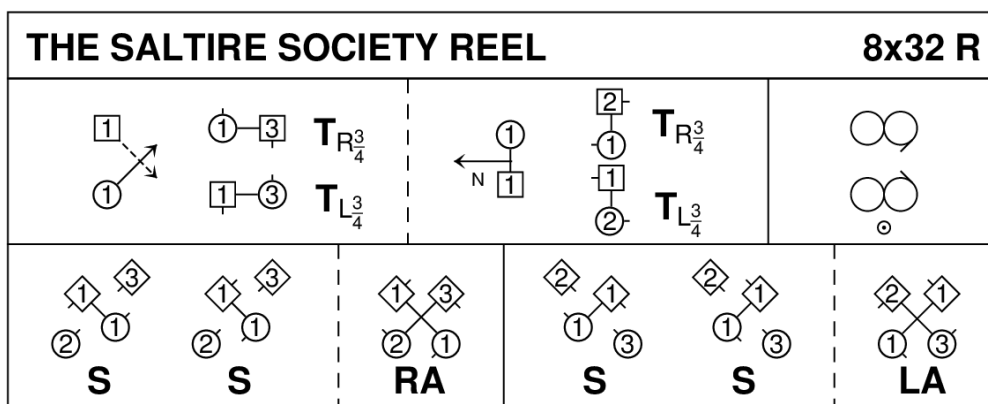

Roy Goldring, 1985, RSCDS Leaflet 9

3C/4C longwise set.

The Gentleman

THE GENTLEMAN (S8x32) 3C (4C set) Roz Scott Huxley RSCDS Bk 35

1- 8 1s turn 2H and remain in middle facing each other as 2s step up, 1s+2s set (1s advancing and pass LSh to face opposite partner) and dance ½ reel of 4 across with 2s with 1s ending reel giving LH to face down on own side between 2s
 9-16 1s dance down to end between 3s and face each other, 1s+3s set (1s advancing and pass LSh to face opposite partner) and ½ reel of 4 across with 3s 1s end giving LH to face up on own side between 3s
 17-24 1s lead up to top, cross over and cast to 2nd place and ½ reels of 3 across (L with 2s and M with 3s)
 25-32 2s+1s dance Diamond Poussette. 213

(MINICRIB, Dance Crib compiled by Charles Upton, Deeside Caledonian Society, and his successors)

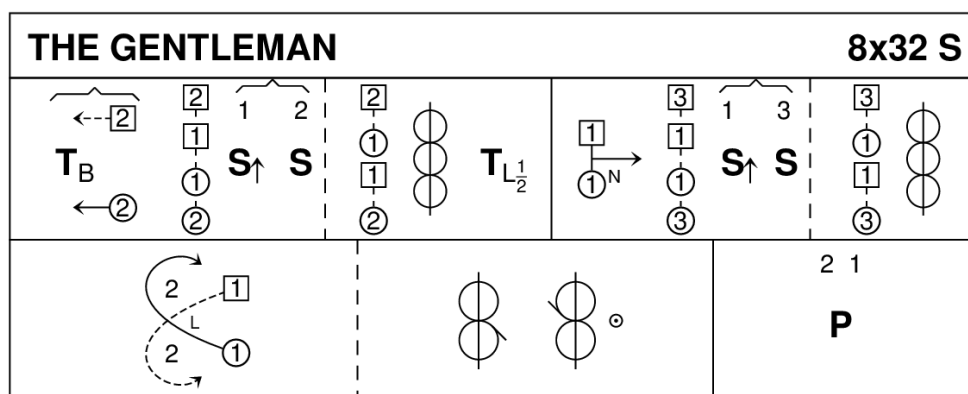

Roz Scott Huxley, 1986, RSCDS Book 35.5

3C/4C longwise set.

The Earl Of Errol's Reel

The Earl Of Errol's Reel

Mary Isdal MacNab S C D Volume 1

Jig 200 bars 3 Couple Repeat 3 Couple Set Lengthwise Set

Part I:

- 1-4** 1s set and lead down one place WHILE 2s step up;
- 5-8** 1s set and lead down one place WHILE 3s step up;
- 9-12** 1s set and cross by the right, finishing on opposite sides facing up, 3s facing down;
- 13-16** 3M1L 3L1M set facing and cross by the left on the sides;
- 17-20** 2M1L 2L1M set facing and turn by the right halfway, all finishing in original places;
- 21-24** all turn partners by the right;
- 25-32** 1s2s3s poussette, finishing 2s3s1s;
- 33-64** Repeat bars 1-32, 2s dancing as 1s, 3s as 2s, 1s as 3s, finishing 3s1s2s;
- 65-96** Repeat bars 1-32, 3s dancing as 1s, 1s as 2s, 2s as 3s, all finishing in original places, 2s facing down, 3s up.

Part II:

- 97-100** grand chain for two places and set facing the next dancer;
- 100-108** repeat bars 97-100 twice, all finishing in original places;
- 108-112** all turn partners by the right.

Part III:

- 113-114** 1L3M turn by the right;
- 115-116** 1s 3s turn by the left;
- 117-118** 1L2M 3M2L turn by the right;
- 119-120** 1L3M touch right hands and return to places;
- 121-122** 1M3L turn by the right;
- 123-124** 1s 3s turn by the left;
- 125-126** 3L2M 1M2L turn by the right;
- 127-128** 1M3L touch right hands and return to places;
- 129-130** 2s turn by the right halfway;
- 131-132** 2L1M 2M3L turn by the left;
- 133-134** 2s turn by the right;
- 135-136** 2L3M 2M1L turn by the left;
- 137-140** 2s turn by the right ¾, slowly;
- 140-144** all turn by the right.

Part IV:

145-146 3M dance (pas-de-basque) partial (¼) petronella turn to finish facing down on the centre line;

147-148 3L full (¾) petronella turn to finish facing down;

149-152 2s repeat bars 145-148;

153-156 1s repeat bars 145-148, finishing 1L1M2L2M3L3M on the centre line, all facing down;

157-160 all set twice, turning on the spot, finishing facing down;

161-166 1L dance down the line passing alternately by the left and the right;

167-168 all dance backwards one place in the line;

169-176 1M repeat bars 161-168;

177-184 2L repeat bars 161-168;

185-190 2M repeat bars 161-166;

191-191 all with pas-de-basque, Mn travel diagonally backwards to their side line facing out WHILE Ls travel backwards up the centre line;

192-192 on the second step of pas-de-basque, Mn turn about and advance WHILE Ls retire towards their side line, finishing ready for poussette;

193-200 3s1s2s poussette, finishing 1s2s3s.

(MAXICRIB, Scottish country dancing instructions compiled by Reuben Freemantle)

THE EARL OF ERROL'S REEL			3 couple set			200 J		
Part 1			3-1	2-1	1 2 3	2 3 1	3 1 2	
S → ₁	S → ₁	S X _R	S X _L	S X _R X _L	T _R	P	R	R
					1 2 3			
					32 bars			32 bars
Part 2								
1 2-3	1-3 2	3 1-2						1 2 3
X _R	X _L	S			R	R		T _R
1 2-3	1-3 2	3 1-2						
	1 bar	1 bar						
Part 3								
1 2 3	2-3	2 3						3
T _R ³	T _L ³	T _R ¹						R
1 2 3	1 2 3	1-2			1 2			1
		Touch R hands						
Part 4								
2	2-3	2	1-2					1 2 3
T _R ¹	T _L	T _R ³	T _L ³					T _R
2	1-2	2	2-3					
Part 4								
3 S	2 S	1 S						1-1 2-2 3-3
								S ₂
Part 4								
1 2 3	1 2 3	2						3 1 2
		R						P
								to 1 2 3

RSCDS MacNab Dances 1

3C/3C longwise set

A Trip To Bavaria

A TRIP TO BAVARIA (R4x32) 4C set James MacGregor-Brown Collins Pocket Ref

1- 4 1s and 4s cross RH while 2s+3s dance ½ RH across, 1s+3s and 2s+4s change places LH on sides
 5- 16 Repeat 1-4 another 3 times (end couples cross RH, middle couples ½ RH across; couples in 1st+2nd place also 3rd+4th place change places LH) All finish in original places
 17-24 1s set to 2s and cross over to face 3s, set and cross to face 4s
 25-32 1s set to 4s and cross over to 4th place on opposite sides, all Adv+Ret 2 steps and 1s change places RH (2H popular) to retire to own sides. 2341

(MINICRIB, Dance Crib compiled by Charles Upton, Deeside Caledonian Society, and his successors)

A TRIP TO BAVARIA						4x32 R			
1	2 3	4	1-3 2-4			1-2	1 3	1 4	2 3 4 1x
X _R	RA	X _R	X _L	X _L	Repeat	S	R	R	↑ T _R ¹ ↓
1		4	1-3 2-4		3 times	1-2			
					to places				

James MacGregor-Brown, Guide to Scottish Country Dancing

4C/4C longwise set

City Of Belfast

CITY OF BELFAST (S3x32) 3C set Lucy Mullholland Belfast Diamond Jubilee Bk

1- 8 1s dance ½ Fig of 8 round 2s, 1L+2M turn RH 1¼ times while 1M+2L turn LH 1¼ times and 1s end BtoB facing opposite sides
 9-16 1s+2s dance reel of 4 across and 2s end in 1st places while 1s pass LSh to face 1st corners
 17-24 1s set to 1st corner and 2nd corner ending (turning to right) between corners, all set and 1s cross RH
 25-32 1s+3s dance Espagnole:-
 ' 25-26 1s+3s cross (Ladies lead across RH passing between Men) with Ladies changing places RH
 ' 27-28 1s+3s cross back (Men lead across RH between Ladies) with Men changing places RH
 ' 29-32 3s turn RH as 1s turn LH to end 231

(MINICRIB, Dance Crib compiled by Charles Upton, Deeside Caledonian Society, and his successors)

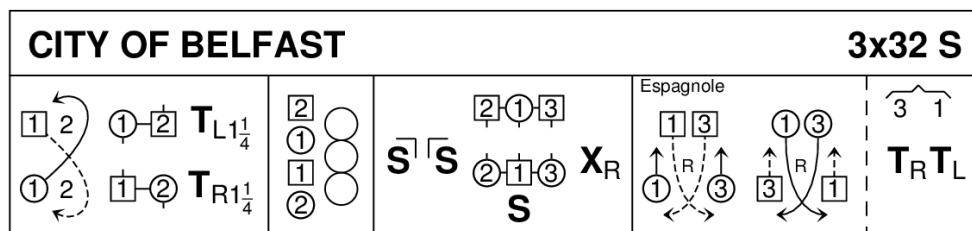

Lucy Mulholland, 2007, Belfast Diamond Jubilee Book, RSCDS Book 48.6

3C/3C longwise set.

Flora's Fancy

FLORA'S FANCY (J8x32) 3C (4C set) RSCDS Tucson and 7 Pipers Scottish Soc. RSCDS Bk 49

1- 8 1s set, cast (2s step up). 1L+2s also 1M+3s dance RH across. 1s finish in middle facing up, 1M following 1L
 9-16 1s (in tandem) +2s dance reel of 3 across (1s pass 2L RSh). 1s end in 2nd place own sides
 17-24 1s set, turn ¼ RH to face own sides. 1L+2s also 1M+3s dance LH across. 1s finish in middle facing down, 1L following 1M
 25-32 1s (in tandem) +3s dance reel of 3 across (1s pass 3M RSh). 1s end in 2nd place own sides

(MINICRIB, Dance Crib compiled by Charles Upton, Deeside Caledonian Society, and his successors)

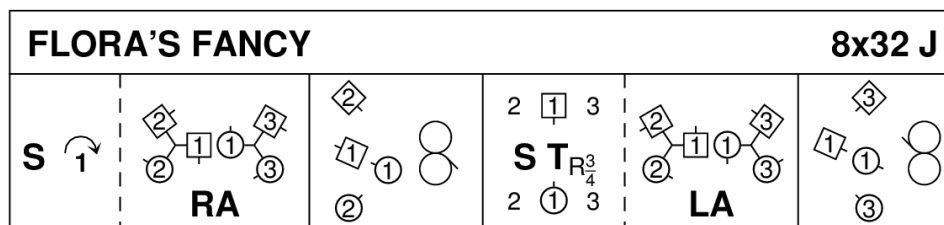

RSCDS Tucson & Seven Pipers Scottish Society, RSCDS Book 49.8

3C/4C longwise set.

Schiehallion

SCHIEHALLION (M-(S64+R64)) Sq.Set Hugh A Thurston

Strathspey

1-16 All dance Chorus:-

' Grand Chain ½ way, set Highland Schottische, Grand Chain ½ way and set Highland Schottische and Men end BtoB in the middle facing partners

17-24 Men set (rocking step) as Ladies petronella turn and set, petronella turn and set to move ½ way round set

25-32 Ladies change places RH with opposite Man, Ladies dance LH across ½ way and turn partners RH

33-48 Repeat bars 1-16 (Chorus)

49-56 All dance RH across ½ way (Men on outside), all change places with partners advancing 1 place and change places again advancing 1 more place

57-64 All repeat bars 49-56 back to places

Reel

1-16 All dance Chorus:-

' Grand Chain ½ way, turn partner with R arms twice, Grand Chain ½ way and turn partner R arms twice
 17-32 1s+3s set advancing, turn opposite dancer and circle 4H round to left, 2s+4s repeat
 33-48 Repeat bars 1-16 (Chorus)
 49-64 All dance full Schiehallion Reels (Men start by crossing to the right, Ladies cast and cross (following partner))

(MINICRIB, Dance Crib compiled by Charles Upton, Deeside Caledonian Society, and his successors)

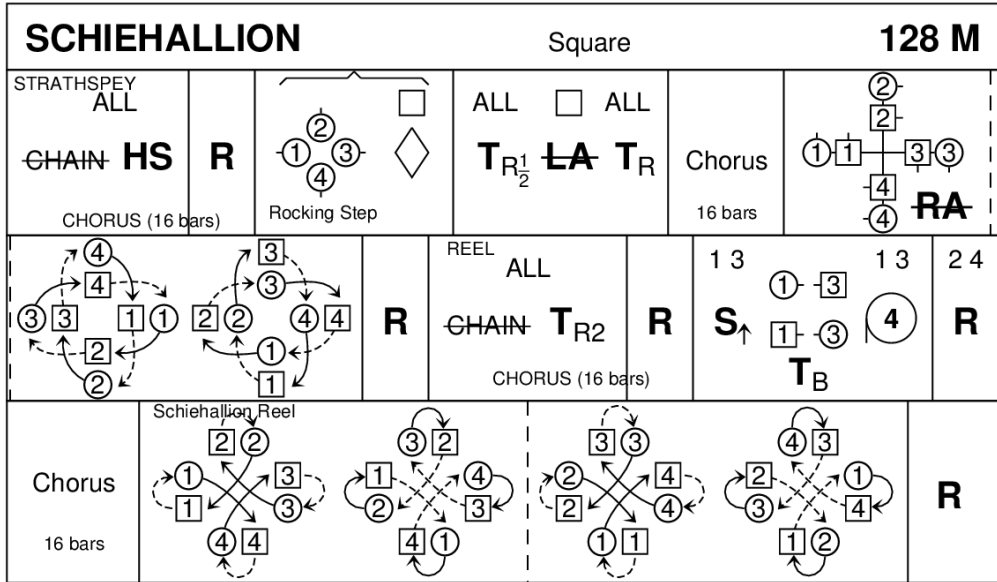

Hugh A Thurston, Leaflet

4C/4C square set.

INTERVAL

The Bees Of MaggieKnockater

THE BEES OF MAGGIEKNOCKATER (J4x32) 4C set John Drewry Canadian Bk

1- 8 1s cross RH and cast 1 place, dance RH across with 3s and end 1M+3L also 1L+3M in prom hold facing out to pass corner person RSh
 9-24 All dance 4x½ Reels of 3 on sides (to right to start, then left, right and left) with 1s+3s changing partners in centre at end of each ½ Reel to progress Men clockwise and Ladies anticlockwise. End in centre 1s facing down and 3s facing up
 25-32 1s dance between 3s turning 3s with nearer hand 1½ times, crossing over to own sides and turn 4th person 1½ times (Men RH and Ladies LH). 2341

(MINICRIB, Dance Crib compiled by Charles Upton, Deeside Caledonian Society, and his successors)

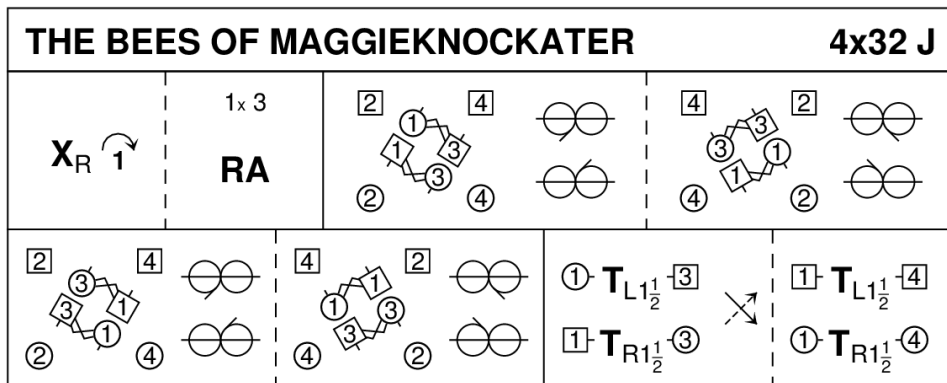

John Drewry, 1975, Canadian Book

4C/4C longwise set.

Starlight

STARLIGHT (R8x32) 3C (4C set) Ed Abdill RSCDS Bk 44

1- 8 1s cross RH, cast 1 place, pas-de-basque in turn right about to face opposite sides and set as double triangles
 9-16 1s dance out, cast round 1st corners into centre while 2s+3s Adv+Ret diagonally, 1s pas-de-basque towards each other and turn right about to face up/down and set as double triangles
 17-24 1s dance up/down, cast to right to 2nd place own sides while 2s+3s Adv+Ret, 1s dance RH across (1L with 2s and 1M +3s) end facing 1st corners
 25-32 1s dance 'Hello-Goodbye' setting ending with petronella turn to 2nd places

(MINICRIB, Dance Crib compiled by Charles Upton, Deeside Caledonian Society, and his successors)

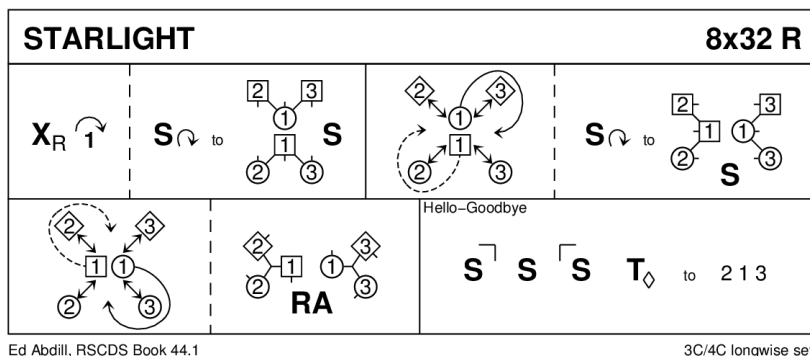

The Duchess Tree

THE DUCHESS TREE (S8x32) 3C (4C set) John Drewry Brodie Bk

1- 8 2s cross up and dance reels of 3 on opposite sides, 2s end in 2nd places opposite side as 1s and 3s end in middle 1s facing down and 3s up
 9-16 All set, circle left for 2 bars, Men turn Lady on right 2H once round and continue circle to places
 17-24 1s+2s dance RH across and end facing up, 1s cast 1 place and lead up while 2s lead up crossing and cast 1 place
 25-32 1s+2s dance Allemande

(MINICRIB, Dance Crib compiled by Charles Upton, Deeside Caledonian Society, and his successors)

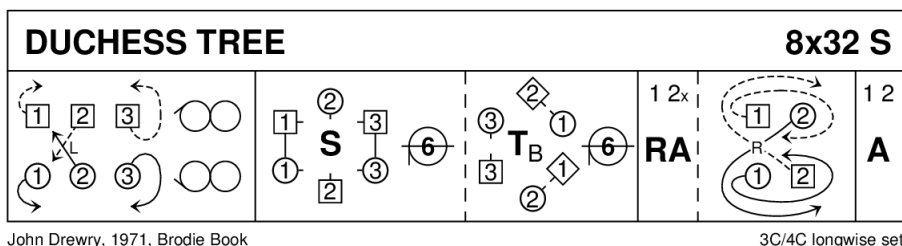

The Diamond Jubilee

THE DIAMOND JUBILEE (J4x32) 4C set Robert M Campbell RSCDS Bk 31

1- 8 1s and 4s turn 1½ times RH and cast 1 place, 1M and 4M also 1L and 4L turn LH on sides to end 1s facing up and 4s down.
 2(1)(4)3
 9-16 All dance reels of 4 on sides (1s and 4s do not fully complete reel but turn right about into centre BtoB facing corner just passed).
 2(4)(1)3
 17-24 4s and 1s set to corners and change places RH, set and change back LH
 25-32 1s+4s dance RH across while 2s and 3s set and cross RH, all set and cross RH back to places. 2413

(MINICRIB, Dance Crib compiled by Charles Upton, Deeside Caledonian Society, and his successors)

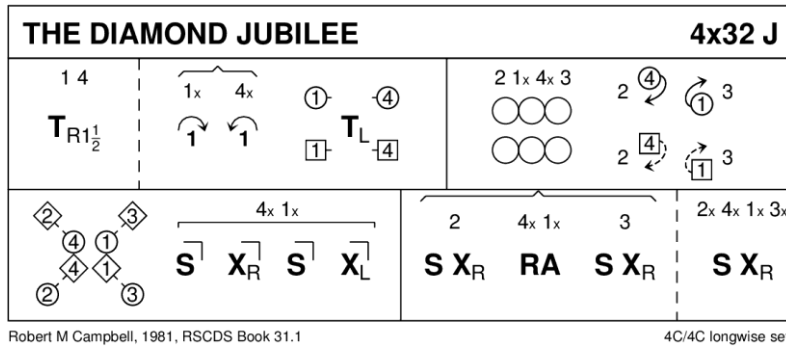

Red House

RED HOUSE (Where Would Bonnie Annie Lie) (R8x40) 2C (4C set) Playford RSCDS Bk 7

1- 8 1s set and cast 1 place, set and cast back to original places

9-16 1M (followed by partner) casts 1 place, dances up between 2s and casts down behind 2L, crosses over and both end in 2nd place own side

17-24 1L (followed by partner) casts up to top, dances down between 2s and casts up behind 2M and crosses over and both end in original places

25-32 1s reel with 2M on Men's side (1M and 2M pass LSh and 1L dances to 2nd place on Men's side to pass partner RSh (1L ends in own place and 1M in 2nd place)

33-40 1s reel with 2L on Ladies' side (1L and 2L pass RSh and 1M dances to 2nd place on Ladies' side to pass partner LSh (1s end in 2nd place own side)

(MINICRIB, Dance Crib compiled by Charles Upton, Deeside Caledonian Society, and his successors)

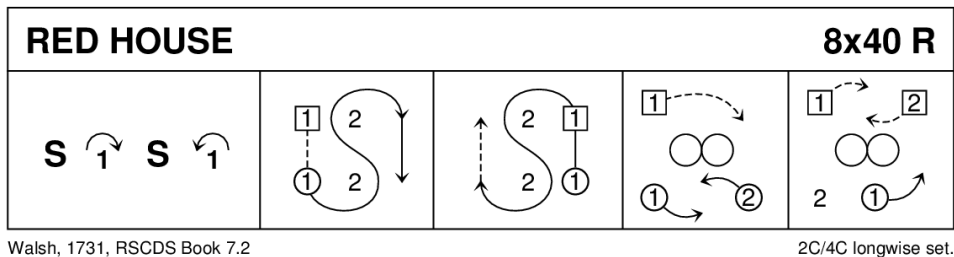

The Minister On The Loch

THE MINISTER ON THE LOCH (S3x32) 3C set Roy Goldring 24 G and S Dances

1- 8 1s+2s dance Diamond Poussette

9-16 1s dance down for 2 steps, turn 2H, dance up to top and turn 2H

17-24 1s+3s dance double Fig of 8 round 2s with 1s casting to start

25-32 1M+2M turn LH 1½ times while 1L+2L turn RH 1½ times, 1M+3M turn RH 1½ times while 1L+3L turn LH 1½ times

(MINICRIB, Dance Crib compiled by Charles Upton, Deeside Caledonian Society, and his successors)

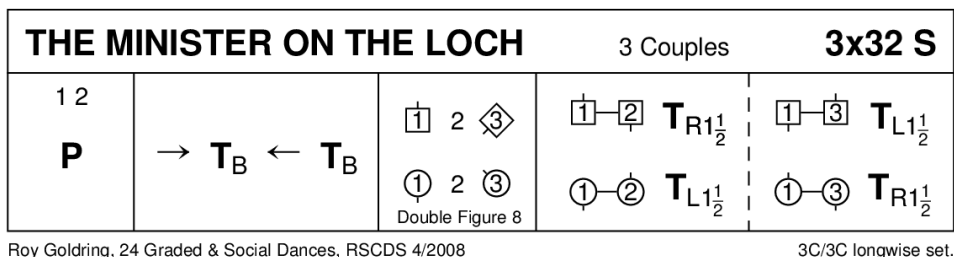

The Iona Cross

THE IONA CROSS (M-S3x32+3xR32) 6C Sq.Set (5s face 1s and 6s face 3s) John W Mitchell Whetherly Bk 17
Dance 3 times Strathspey and 3 times Reel:-

1- 8 1s+5s+6s+3s dance parallel RSh reels of 4 up/down set
9-16 1s+5s and 6s+3s dance DoSiDo as 2s and 4s Adv+Ret, 1s+5s and 6s+3s dance ½ R&L (1s and 3s end facing side couples)
17-24 2s and facing couple (1L+3M) with 4s and facing couple (1M+3L) dance parallel RSh reels of 4 across set
25-32 Each centre dancer (1s and 3s) dances RH across with nearest 2 corner dancers, centre dancers dance LH across once round in centre as outside couples (5s+2s+6s+4s) circle 8H round (or chase) to left ¼ way (quickly) to new pstns with 2s at top, 6s in 2nd place, 4s in 3rd place and 5s in 4th place

(MINICRIB, Dance Crib compiled by Charles Upton, Deeside Caledonian Society, and his successors)

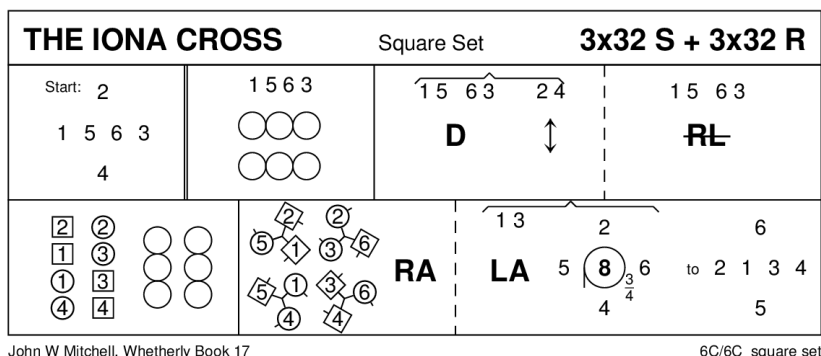

Strip The Willow

STRIP THE WILLOW (Drops Of Brandy) (J4x40) 4C set Running step RSCDS Bk 1

1- 8 1s turn RH 2½ times (4 bars), 1L turns 2M LH then turns partner RH
9-16 1L turns 3M LH, turns partner RH, 1L turns 4M LH and turns partner RH
17-24 1M turns 4L LH, turns partner RH, 1M turns 3L LH and turns partner RH
25-32 1M turns 2L LH, turns partner RH, 1L turns 2M LH as 1M turns 2L LH, 1s turn RH in centre
33-40 1s similarly turn 3s LH, turn partners RH, turn 4s LH and turn partners RH to 4th place own sides (last turn uses the next first 2 bars of music)

(MINICRIB, Dance Crib compiled by Charles Upton, Deeside Caledonian Society, and his successors)

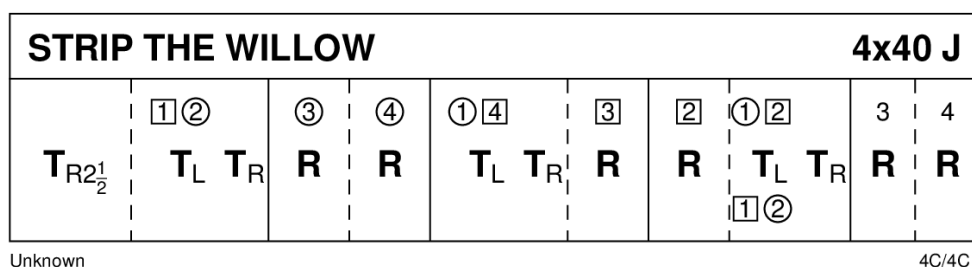

EXTRAS

Best Set In The Hall

BEST SET IN THE HALL (J8x32) 3C (4C set) Helen Greenwood RSCDS Bk 46

1- 8 1s set and 1L followed by partner casts below 3s, 1L crosses and casts up to face her 1st corner while 1M dances up the middle to face 1st corner
9-12 1s set to 1st corners and dance RSh round each other into 3rd corner (pstn) while 1st corners dance in and turn right about to face their original position
13-16 1s+1st corner person set and 1st corner persons dance RSh round each other into diag opposite corners while 1s dance in and

pivot to right to face 2nd corners
 17-24 1s repeat bars 9-16 with 2nd corners and end passing RSh to 2nd place opposite sides. (3)(1)(2)
 25-32 2s+1s+3s chase clockwise ½ way and turn partners RH

(MINICRIB, Dance Crib compiled by Charles Upton, Deeside Caledonian Society, and his successors)

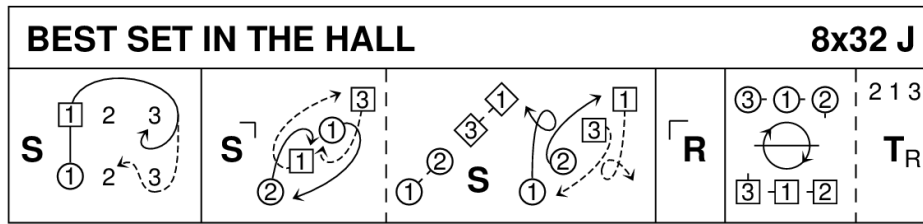

Helen Greenwood, 2003, RSCDS Book 46.7

3C/4C longwise set.

The Triumph

THE TRIUMPH (R4x24) 4C set Nathaniel Gow RSCDS Bk 1

1- 8 1s lead down the middle and back to top, 1M presenting 1L to 2M
 9-16 1L+2M with nearer hands joined dance down the middle followed by 1M, 1L+2M turn inwards (holding hands) and with crossed arms gives LH to partner, 1M+2M join free hands in arch over Ladies head and all 3 dance up in "Triumph", 2M returns to place
 17-24 1s dance special Poussette (¼ turn, travel, ¼ turn, ¼ turn, travel, ¼ turn, ½ turn) down the middle to 4th place as 2s+3s+4s step up

(MINICRIB, Dance Crib compiled by Charles Upton, Deeside Caledonian Society, and his successors)

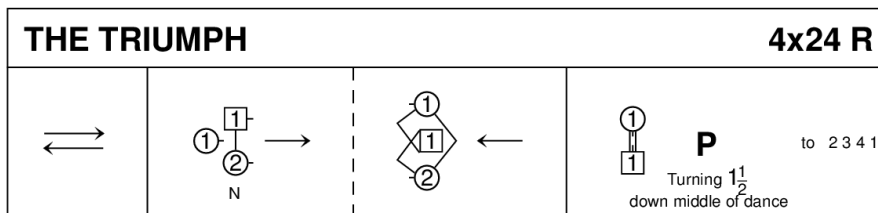

Nathaniel Gow, 1808, RSCDS Book 1.2

4C/4C longwise set.

Sands Of Morar

SANDS OF MORAR (S8x32) 3C (4C set) Barry Priddey RSCDS Bk 45

1- 8 1s dance Fig of 8 round 2s giving hands when possible
 9-16 1s dance reflection reels of 3 on own sides (1s dance down between 2s to begin)
 17-24 1s turn 2H and dance down middle to 3rd place as 2s+3s continue reel and dance down behind 1s, all set and 1s followed by 2s+3s cast up to original places
 25-32 1s+2s dance the Tourbillon:-
 ' 1s and 2s turn partners 2H ½ way, 1M and 2L lead partners on 1 place clockwise to end 1s on Ladies' side and 2s on Men's side, 1s set to 2s
 ' 1s and 2s ½ turn partners 2H, 1L and 2M lead partners on 1 place to end 2s in 1st place and 1s in 2nd place and 2s+1s cross RH to own sides (MINICRIB, Dance Crib compiled by Charles Upton, Deeside Caledonian Society, and his successors)

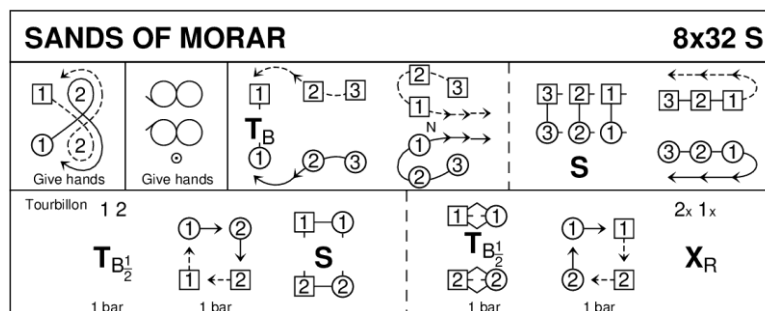

Barry Priddey, 1983, Glasgow Diamond Jubilee & RSCDS Book 45.6

3C/4C longwise set.