

**1. HOOPER'S JIG (J8x32) 3C (4C set) MMM 2**

1- 8 All clap and 1s cross passing RSh, cast to 2nd place and dance RH across with 3s  
 9-16 All clap and 1s cross passing RSh, cast to 1st place and dance LH across with 2s  
 17-24 1M+3L change places RH and 1L+3M change places RH (as 1M+3L loop round), 1M+3L change places RH (as 1L+3M loop round) and 1L+3M cross LH 1L ending in 2nd place (as 1M casts to 2nd place)  
 25-32 2s+1s dance R&L

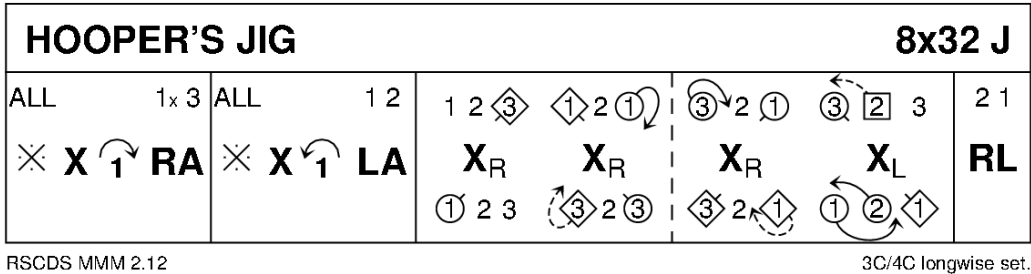

**2. CATCH THE WIND (R8x32) 3C (4C set) Romaine Butterfield RSCDS Book 45**

1- 8 1s set, cast 1 place and dance ½ Fig of 8 round 2s  
 9-16 1s set twice with 1L turning to face out, 1L followed by partner casts up and dances down the middle 1L to face 3M while 1M faces 2M  
 17-24 1s RSh reels of 3 across (1M with 2s and 1L with 3s)  
 25-32 1L followed by partner dances down cast up round 3M and crosses to end in 2nd place on own sides, 1s turn RH (4 bars)

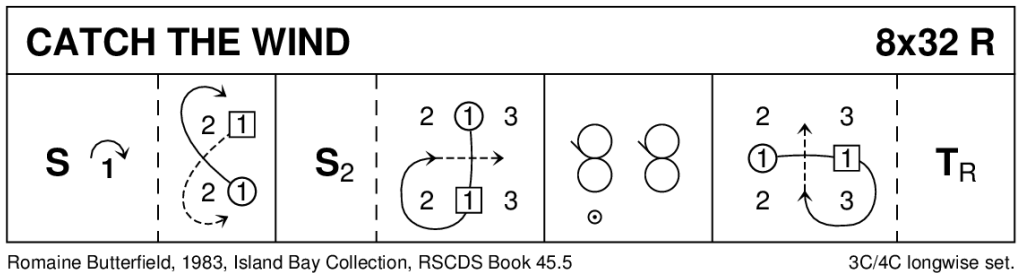

**3. TRIPLE HAPPINESS (S3x32) 3C Yoshiki Oyama RSCDS Book 52**

1- 8 1s Adv&Ret (1 step each) touching hands, 1s ½ turn LH, cross down between 2s and 3s, cast up to place  
 9-16 1s+2s dance the Knot. 1s end facing 1st corners  
 17-24 Corners Pass&Turn with 1st corners, pass RSh, Repeat with 2nd corner and 1s pass RSh into 2nd place own sides (corners turn 2H in centre)  
 25-32 All chase clockwise ½ round to opposite sides, all ½ turn 2H, pull back RSh and dance out to own sides. 312

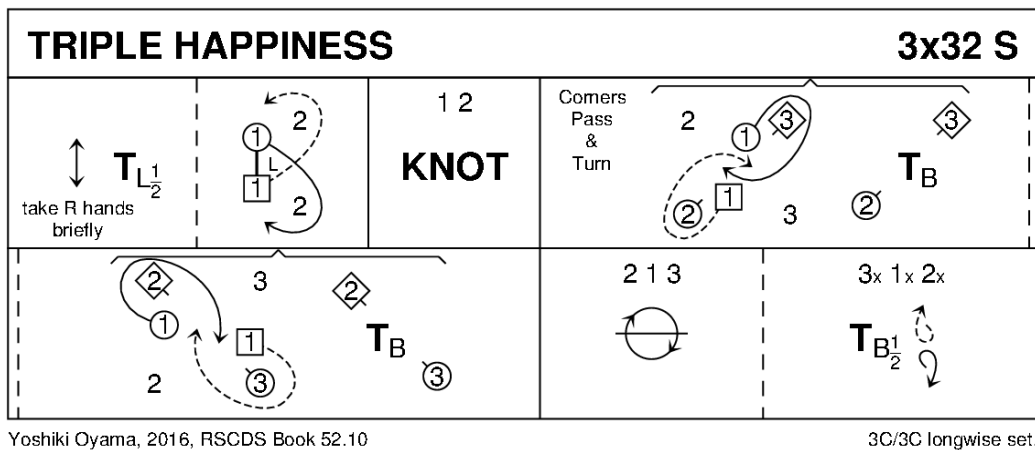

**4. SWISS LASSIE (R8x32) 3C (4C set) Rosi Betsche RSCDS Book 39**

1- 8 1s dance in and cast to 3rd place, 2s+1s turn partners RH  $1\frac{1}{4}$  times to form a line Up&Down middle of set (Men facing down Ladies up)  
 9-16 2s+1s dance reel of 4 Up&Down middle of set ending with 2M facing Ladies' side and 1L facing Men's side  
 17-24 2s+1s chase round clockwise  $\frac{1}{2}$  way, 1s+3s+2s Adv&Ret  
 25-32 3s+2s (bottom 2 couples)  $\frac{1}{2}$  turn partners RH, dance RH across  $\frac{1}{2}$  way, 1s+2s (top 2 couples)  $\frac{1}{2}$  turn partners RH and dance RH across  $\frac{1}{2}$  way

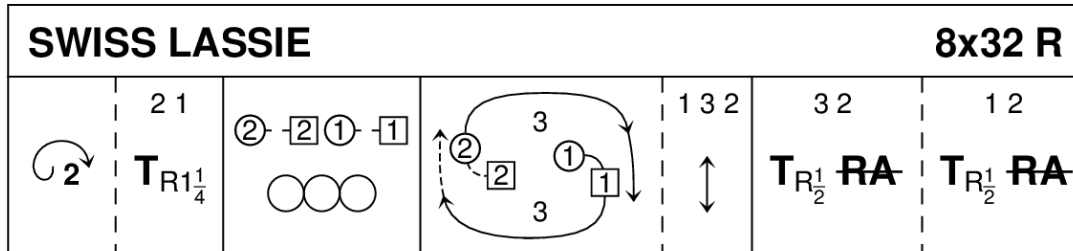

Rosi Betsche, RSCDS Book 39.1

3C/4C longwise set.

**5. CITY LIGHTS (J8x32) 3C (4C set) Nicola Scott RSCDS Bk 52**

1- 8 1s turn RH, cast (2s step up), turn  $1\frac{1}{4}$  LH to face 1st corners  
 9-12 Corners Pass and Allemande Turn:-  
 ' As Corners Pass&Turn except corners dance in, join RH and Lady dances under Man's arm. Lady curves out to place as Man retires.  
 13-16 1s in centre turn  $1\frac{1}{4}$  LH to face 2nd corner positions while corners chase clockwise  $\frac{1}{2}$  round  
 17-24 Repeat 9-16 with 2nd corner positions. 1s end in centre LSh to LSh facing opposite sides  
 25-32 1L+2s and 1M+3s dance RH across; all turn partners RH (or birl) 213

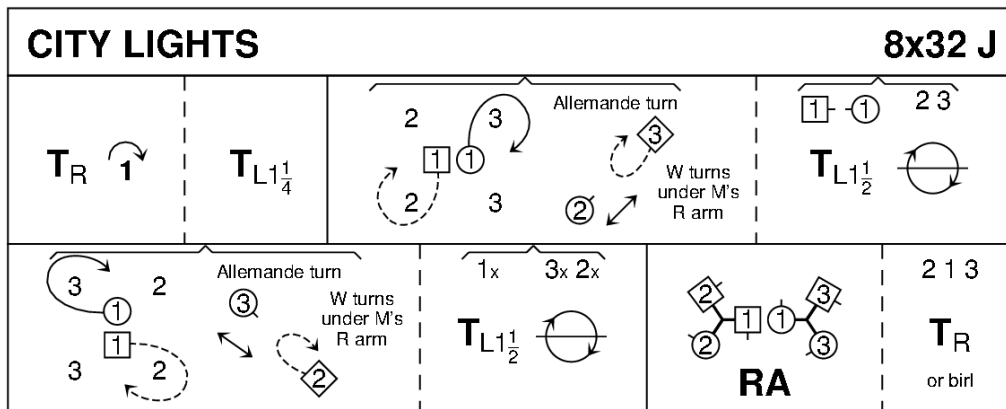

Nicola Scott, 2015, RSCDS Book 52.1

3C/4C longwise set.

**6. SANDS OF MORAR (S8x32) 3C (4C set) Barry Priddey RSCDS Book 45**

1- 8 1s dance Fig of 8 round 2s giving hands when possible  
 9-16 1s dance reflection reels of 3 on own sides (1s dance down between 2s to begin)  
 17-24 1s turn 2H and dance down middle to 3rd place as 2s+3s continue reel and dance down behind 1s, all set and 1s followed by 2s+3s cast up to original places  
 25-32 1s+2s dance the Tourbillon:-  
 ' 1s and 2s turn partners 2H  $\frac{1}{2}$  way, 1M and 2L lead partners on 1 place clockwise to end 1s on Ladies' side and 2s on Men's side, 1s set to 2s  
 ' 1s and 2s  $\frac{1}{2}$  turn partners 2H, 1L and 2M lead partners on 1 place to end 2s in 1st place and 1s in 2nd place and 2s+1s cross RH to own sides

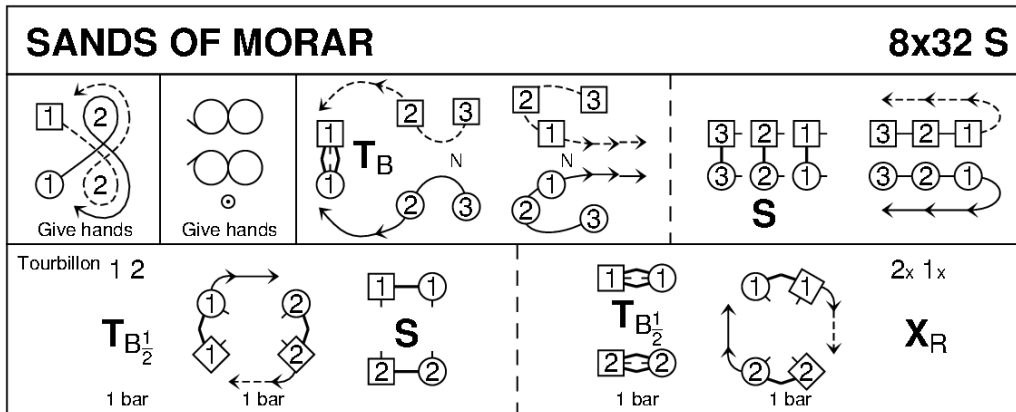

Barry Priddey, 1983, Glasgow Diamond Jubilee & RSCDS Book 45.6

3C/4C longwise set.

### 7. CASTLE OF MEY (R8x32) 3C (4C set) John Walton RSCDS Diamond Jubilee

- 1- 8 1s dance Inveran reels with 2s+3s
- 9-16 1s+2s dance double Figs of 8 (1s start by crossing down)
- 17-24 1s lead down the middle and up, 1s end in middle of the set
- 25-32 1s+2s dance Poussette

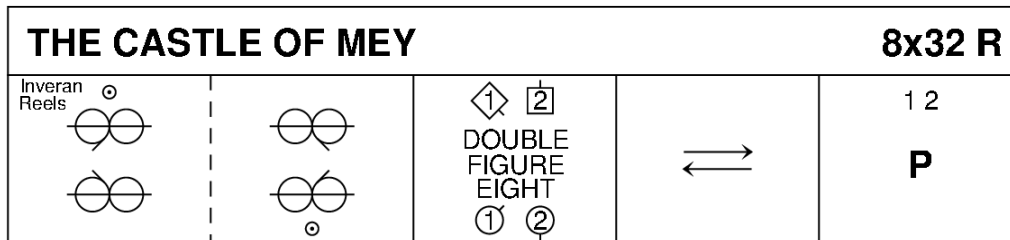

John Walton, 2012, RSCDS QE Diamond Jubilee

3C/4C longwise set.

### 8. THE FIRST RAIN OF SPRING (J3x32) 3C Wouter Joubert RSCDS Book 49

- 1- 8 1s dance down, cast up round 3s, meet, dance up to 1st place facing out. 1s+2s 1/2 turn (Men LH, Ladies RH)
- 9-16 2s+1s dance double Figs 8 (1s cross up, 2s cast to start)
- 17-20 1s+3s 3/4 turn RH into line up/down in middle facing partner and set
- 21-28 1s+3s dance 1/2 Celtic Reel:-
  - ' 21-22 1s+3s pass partner RSh
  - ' 23-24 1M+3L dance clockwise while 1L+3M dance 3/4 round each other LSh to face partners in line across
  - ' 25-26 1s+3s pass partner RSh
  - ' 27-28 1L+3M dance clockwise while 1M+3L dance 3/4 round each other LSh to face partners in line up/down set
- 29-32 3s+1s 3/4 turn partners RH to side lines and 2s+3s+1s set

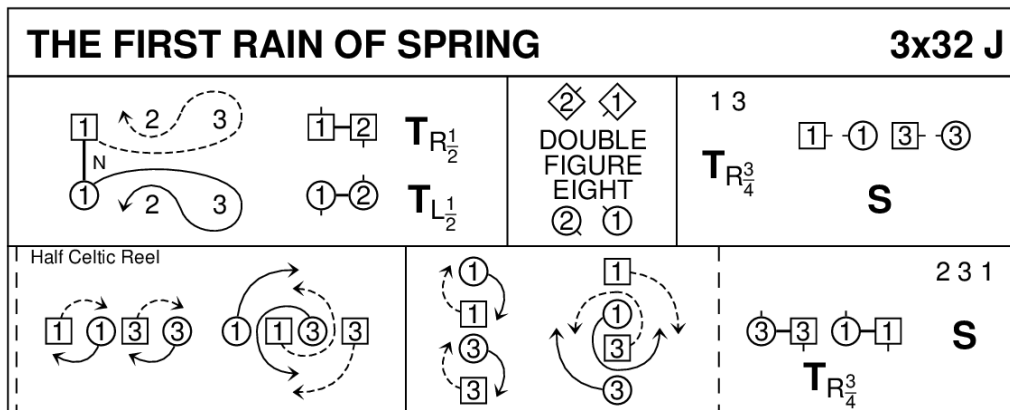

Wouter Joubert, 2013, RSCDS Book 49.4

3C/3C longwise set.

**9. GANG THE SAME GATE (S8x32) 3C (4C set) Milton Levy RSCDS Book 36**

1- 8 1s cross RH and cast down to 3rd place, cross RH and cast up to 2nd place on own sides  
 9-16 1s set adv to partner and turn 1st corner 2H to face 2nd corner, 1s dance ½ diagonal reel of 4 ending M between top couple facing down and L between bottom couple facing up  
 17-24 1s set adv to partner and turn 4th corner (pstn) 2H to face own 1st corner (pstn), 1s dance ½ diagonal reel with 1st corners ending in 2nd place opposite sides  
 25-32 3s+1s+2s Set&Link for 3 twice. 213

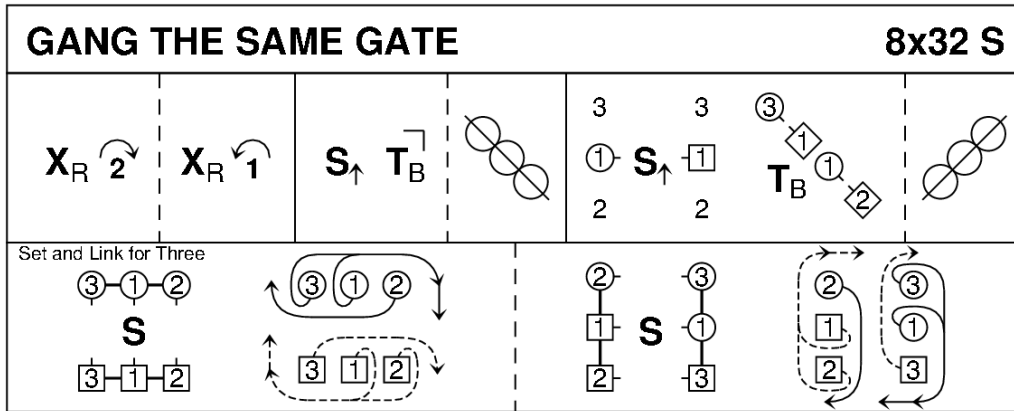

Milton Levy, RSCDS Book 36.4

3C/4C longwise set.

**10. MAXWELL'S RANT (R8x32) 3C (4C set) David Rutherford RSCDS Book 18**

1- 8 1s cross down to dance reflection reels of 3 on opposite sides  
 9-16 1s cross down to dance reflection reels of 3 on own sides  
 17-24 1s cross RH, cast to 2nd place and dance ½ Fig of 8 round 2s  
 25-32 1s dance down between the 3s, cast up to 2nd place and 2s+1s+3s turn partners RH. 213

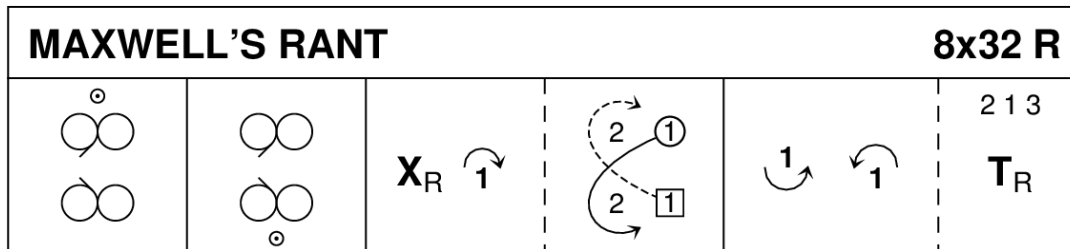

Rutherford, 1752, RSCDS Book 18.10

3C/4C longwise set.

**11. THE WILD GEESE (J8x32) 3C (4C set) RSCDS Book 24**

1- 8 1s+3s set advancing and Balance-in-Line (Man above Lady), turn partners RH and 1s cast to 3rd place while 3s lead up to 1st place  
 9-16 3s+1s set advancing and Balance-in-Line (Man above Lady), turn partners RH and 3s cast to 3rd place while 1s lead up to 1st place  
 17-24 1s lead down and back to 2nd place  
 25-32 2s+1s dance R&L. 213

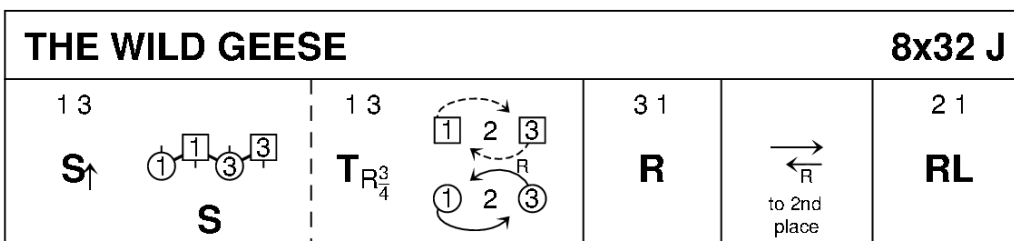

RSCDS Book 24.3

3C/4C longwise set.

**12. CITY OF BELFAST (S3x32) 3C set** Lucy Mullholland Belfast Diamond Jubilee Book and RSCDS Book 48

- 1- 8 1s dance ½ Fig of 8 round 2s, 1L+2M turn RH 1¼ times while 1M+2L turn LH 1¼ times and 1s end BtoB facing opposite sides  
 9-16 1s+2s dance reel of 4 across and 2s end in 1st places while 1s pass LSh to face 1st corners  
 17-24 1s set to 1st corner and 2nd corner ending (turning to right) between corners, all set and 1s cross RH  
 25-32 1s+3s dance Espagnole:-  
 ' 25-26 1s+3s cross (Ladies lead across RH passing between Men) with Ladies changing places RH  
 ' 27-28 1s+3s cross back (Men lead across RH between Ladies) with Men changing places RH  
 ' 29-32 3s turn RH as 1s turn LH. 231

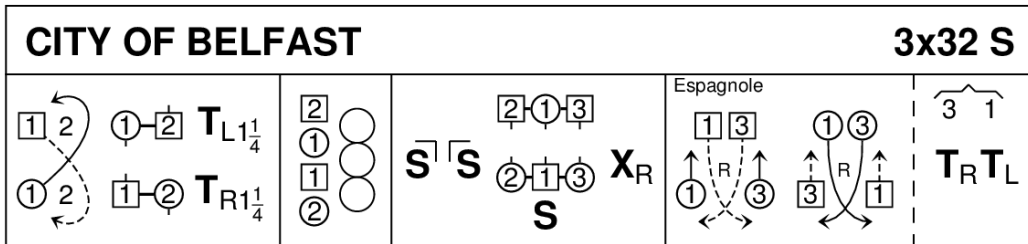

Lucy Mullholland, 2007, Belfast Diamond Jubilee Book, RSCDS Book 48.6

3C/3C longwise set.

**13. MACDONALD OF KEPPOCH (M-(S64+R64)) Sq.Set** Chris Ronald RSCDS Book 49

- 1- 8 1s+3s dance 6 bars R&L (Men polite turns) to finish in centre BtoB with partner facing side couples (1L+2L, 1M+4M, 3L+4L, 3M+2M). All set  
 9-16 Reels of 4 across. Finish in line up/down with Ladies (in middle) facing, 1M facing down, 3M facing up  
 17-24 Reel of 4 (1L+3L pass RSh)- all pass LSh at ends, RSh in middle. Finish in original places facing partners  
 25-32 All set, all turn partner RH 1¼ into promenade hold and dance 1 place anticlockwise.  
 Repeat from new positions in Strathspey then twice in Reel time back to original places

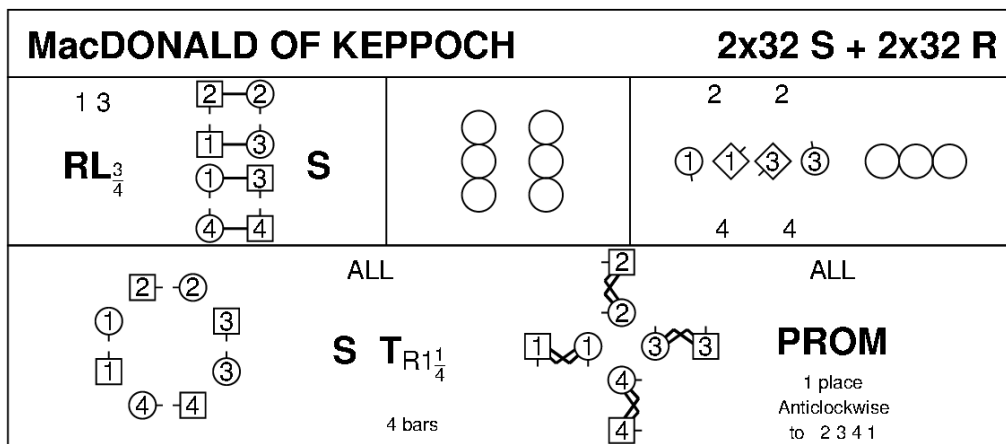

Chris Ronald, 2013, RSCDS Book 49.11

4C/4C square set.

**14. GOTHENBURG'S WELCOME (J8x32) 3C (4C set)** Bobby Munro RSCDS Book 37

- 1- 4 1s cast 1 place and set advancing to 1st corner  
 5-16 1s Dance to Each Corner and Set:-  
 ' 5- 6 1s change places with 1st corners passing RSh and 1st corners pass RSh with a ¼ turn to right in centre to face 2nd corners (as 2nd corners set),  
 ' 7- 8 Original 1st corners change places with 2nd corners passing RSh and 2nd corners pass RSh with a ¼ turn to right to face 1s in 3rd corner (pstn) as 1s set  
 ' 9-10 Original 2nd corners change places with 1s passing RSh and 1s pass RSh with a ¼ turn to right to face 2nd corner (pstn) as original 1st corners set  
 ' 11-16 Repeat this Fig once more until 1s end in centre facing 3rd corner positions with 3s and 2s in 1st and 3rd places opposite sides  
 17-24 1s dance ½ diagonal Reel of 4 with 3rd corner, pass RSh and dance ½ diagonal Reel with 4th corners  
 25-32 1s dance RH hands across (L with 2s and M with 3s) and 2s+1s+3s turn RH

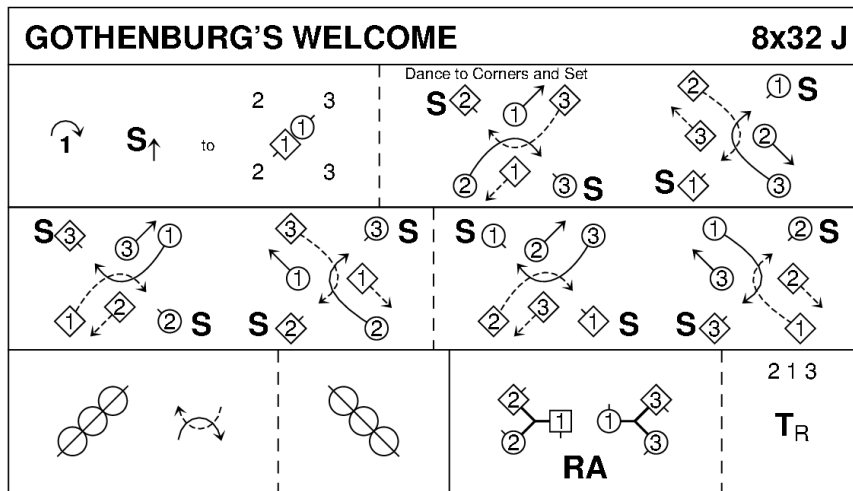

Bobby Munro, RSCDS Book 37.3

3C/4C longwise set.

### 15. ANNE MCARTHUR (S3x32) 3C set Jim Stott Aberdeen 9 for 90 Aberdeen 90th

- 1- 8 1s+2s+3s circle 6H round and back
- 9-16 1s Set&Cast off, 1s turn LH to face 1st corners
- 17-24 1s set and turn 1st corner, set and turn 2nd corner to finish in 2nd place opposite side
- 25-28 2s+1s+3s set. 1s cross RH to 2nd place own side
- 29-32 1s+3s Set&Link

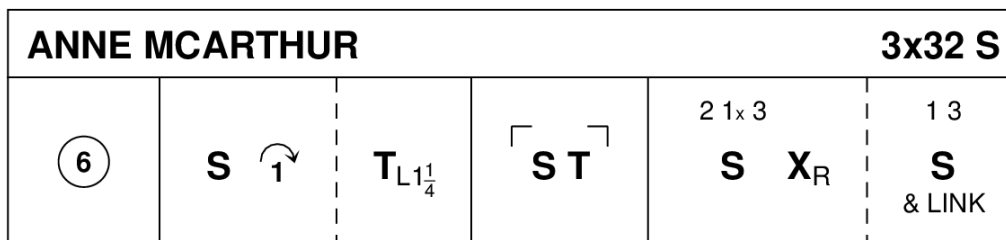

Jim Stott, 2006, 9 for 90 RSCDS Aberdeen Branch

3C/3C longwise set.

### 16. MRS MACPHERSON OF INVERAN (R8x32) 3C (4C set) John Drewry Bon Accord Book

- 1- 8 1s dance Inveran Reels with 2s+3s
- 9-16 1s turn RH 1½ times moving down to 2nd place opposite sides (2s step up); 1s cast up behind 2s and cross down to 2nd place own side
- 17-24 2s+1s+3s dance Grand Chain
- 25-32 2s+1s+3s circle 6H round and back

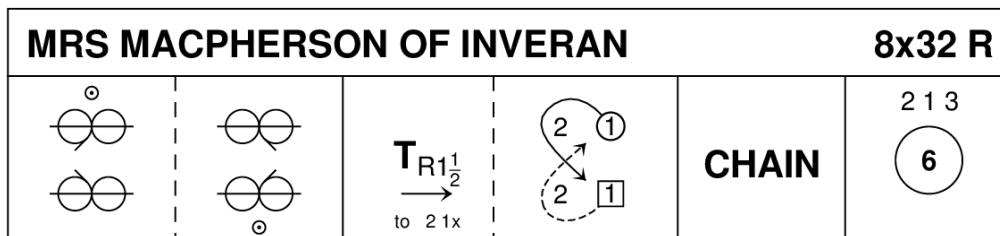

John Drewry, 1964, Bon Accord Book

3C/4C longwise set

#### General info:

MINICRIB, Dance Crib compiled by Charles Upton, Deeside Caledonian Society, and his successors  
 Keith Rose's Crib Diagrams